

# ASME BPE TUBE FITTINGS



**Axium Process specialises in fabrication for the pharmaceutical and biotech industries, designing and manufacturing in accordance with ASME BPE principles. We also supply a range of tube fittings and components which are compliant with the ASME Bioprocessing Equipment Standard.**



**The ASME BPE standard dictates specific conditions for the bioprocessing industry in terms of design, materials, construction, surface finish and inspection.**

ASME BPE Surface Finish			
Surface	Ra Max.		Polishing
Designation	μ-in.	μ-m	Criteria
SF0	No Finish Requirement		
SF1	20	0.51	Mechanical
SF2	25	0.64	Mechanical
SF3	30	0.76	Mechanical
SF4	15	0.38	Electro-Polished
SF5	20	0.51	Electro-Polished
SF6	25	0.64	Electro-Polished

Surface finish designation should be referenced for all ASME BPE fittings, tubes & components

Clamp Ferrule	Nominal Size	Clamp OD A	Bore ID B	Tube OD C	Clamp Length "L"			
					Long	Standard	Short	
	1/4"	24.99	4.57	6.35	44.5	28.7	12.7	
	3/8"	24.99	7.75	9.53	44.5	28.7	12.7	
	1/2"	24.99	9.40	12.70	44.5	28.7	12.7	
	3/4"	24.99	15.75	19.05	44.5	28.7	12.7	
	1"	50.39	22.10	25.40	44.5	28.7	12.7	
	1 1/2"	50.39	34.80	38.10	44.5	28.7	12.7	
	2"	63.91	47.50	50.80	57.2	28.7	12.7	
	<b>Larger sizes available - up to 6"</b>							
	<b>Material = 316L - LS 1.4435</b>							

Clamp Ended 90° Bend		Clamp Ended 90° Bend
Nominal Size	Ctr - Face L	
1/4"	41.3	
3/8"	41.3	
1/2"	41.3	
3/4"	41.3	
1"	50.8	
1 1/2"	69.9	
2"	88.9	
<b>Larger sizes available - up to 6"</b>		
<b>Material = 316L - LS 1.4435</b>		

Clamp Ended 45° Bend		Clamp Ended 45° Bend
Nominal Size	Ctr - Face L	
1/4"	25.4	
3/8"	25.4	
1/2"	25.4	
3/4"	25.4	
1"	28.6	
1 1/2"	36.5	
2"	44.5	
<b>Larger sizes available - up to 6"</b>		
<b>Material = 316L - LS 1.4435</b>		

**DIMENSIONS ARE IN MM UNLESS OTHERWISE STATED.**

**ALL DATA IS PROVIDED IN GOOD FAITH AND IS SUBJECT TO CHANGE.**

**Tel: +44 (0)1792 883882 Web: [www.axiumprocess.com](http://www.axiumprocess.com) Fax: +44 (0)1792 886049**

# ASME BPE TUBE FITTINGS

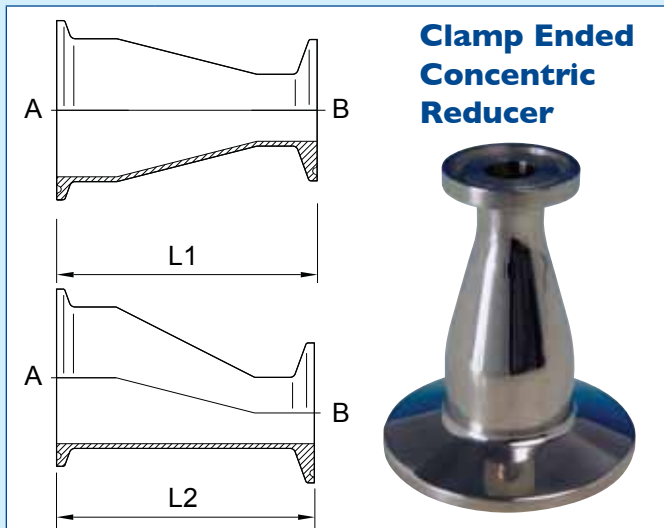

**Clamp Ended Concentric Reducer**

Clamp Ended Concentric & Eccentric Reducers			
Nominal Size		Concentric	Eccentric
A	B	L1	L2
3/4"	1/2"	50.8	50.8
1"	1/2"	63.5	63.5
	3/4"	50.8	50.8
1 1/2"	3/4"	76.2	76.2
	1"	76.2	76.2
2"	1"	127.0	127.0
	1 1/2"	76.2	76.2

Larger sizes available - up to 6"  
Material = 316L - LS 1.4435

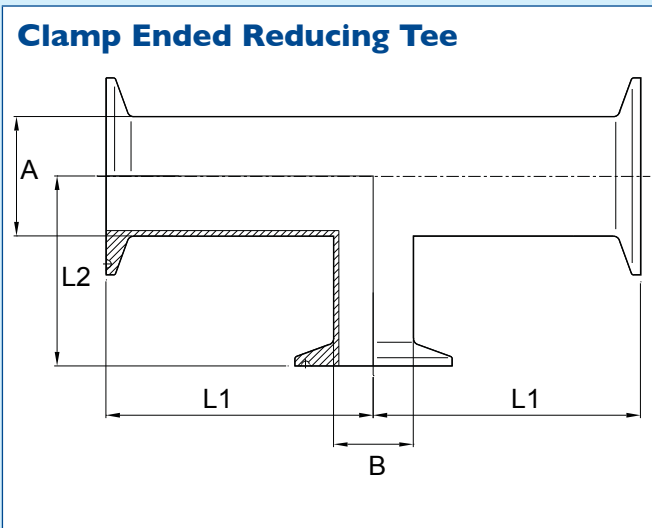

Clamp Ended Reducing Tee			
Nominal Size		Dim	Dim
A	B	L1	L2
3/8"	1/4"	57.2	25.4
1/2"	1/4"	60.3	25.4
	3/8"	60.3	25.4
3/4"	1/4"	63.5	25.4
	3/8"	63.5	25.4
	1/2"	63.5	25.4
1"	1/4"	66.7	28.6
	3/8"	66.7	28.6
	1/2"	66.7	28.6
	3/4"	66.7	28.6
1 1/2"	1/2"	73.0	34.9
	3/4"	73.0	34.9
	1"	73.0	34.9
2"	1/2"	85.7	41.3
	3/4"	85.7	41.3
	1"	85.7	41.3
	1 1/2"	85.7	41.3

Larger sizes available - up to 6"  
Material = 316L - LS 1.4435

Clamp Ended Straight Tee		Clamp Ended Straight Tee
Nominal Size	Ctr - Face Dim 'L'	
1/4"	57.2	
3/8"	57.2	
1/2"	57.2	
3/4"	60.3	
1"	66.7	
1 1/2"	73.0	
2"	85.7	

Larger sizes available - up to 6"  
Material = 316L - LS 1.4435

**We also supply Plain-ended options which are ASME BPE compliant.**

**We specialise in customised fabrication providing engineering solutions to customer requirements.**

**Axium Process Ltd**  
Hendy Industrial Estate, Hendy  
Swansea, UK  
SA4 0XP  
Tel: +44 (0) 1792 883882  
Fax: +44 (0) 1792 886049  
Email: info@axiumprocess.com  
Web: www.axiumprocess.com

