

8085

Plain-ended eccentric reducer - 316L

Nom size Larger	Nom size Smaller	C1	C2	Stock No
1"	1/2"	25.4	12.7	8085-6026-013
1"	3/4"	25.4	19.1	8085-6026-019
1 1/2"	1"	38.1	25.4	8085-6038-026
2"	1"	50.8	25.4	8085-6051-026
2"	1 1/2"	50.8	38.1	8085-6051-038
2 1/2"	1"	63.5	25.4	8085-6064-026
2 1/2"	1 1/2"	63.5	38.1	8085-6064-038
2 1/2"	2"	63.5	50.8	8085-6064-051
3"	1"	76.2	25.4	8085-6076-026
3"	1 1/2"	76.2	38.1	8085-6076-038
3"	2"	76.2	50.8	8085-6076-051
3"	2 1/2"	76.2	63.5	8085-6076-064
4"	1 1/2"	101.6	38.1	8085-6102-038
4"	2"	101.6	50.8	8085-6102-051
4"	2 1/2"	101.6	63.5	8085-6102-064
4"	3"	101.6	76.2	8085-6102-076

Length is subject to change

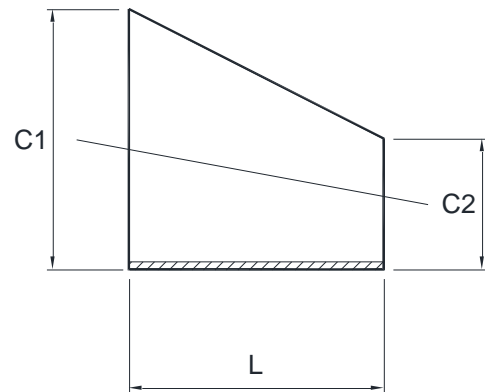

Please contact our sales department for information on Dimension L

TECHNICAL DATA	
Material	316L Stainless Steel
Material Certification	BS EN 10204/DIN 50049 3.1 for all wetted parts
Finish	Welds ground ID & OD, Polished 0.8Ra (0.4 Ra available)
Tolerance	+/- 1.0mm
Plain-Ended Fittings Range	Tees, 90°, 45° & 180° bends, hoesetails, concentric & eccentric reducers, Y pieces, Crosses
Notes	Dimensions are provided in good faith, if critical please contact sales for confirmation Seals must be chosen for required operating medium and temperature
GENERAL CAPABILITIES	
Design and System Fabrication, Hygienic Process Plant, Project Management, In-house Manual and Orbital Welding, Machining, Fabrication and Polishing, Component Customisation	
Full materials certification, weld maps, logs, welder qualifications and weld procedures, pickling, passivation and ferroxyl certification.	

D8085-V03 / ECN 730

CUSTOMISED STAINLESS STEEL SYSTEMS, FABRICATIONS AND COMPONENTS

Axium Process Ltd

Hendy Industrial Estate, Hendy, Swansea, UK SA4 0XP
 Tel: +44 (0) 1792 883882
 Fax: +44 (0) 1792 886049
 Email: info@axiumprocess.com
 Web: www.axiumprocess.com



All data is provided in good faith and is subject to change