

5076

**Clamp bend 90 deg long 316L
BS4825***

Nom size inch	L	R	Rad D	Max Op Pressure (bar) @ 150 C	Stock No
*1"	86.5	38.1	1.5D	10	5076-6026
*1 1/2"	106.5	57.2	1.5D	10	5076-6038
*2"	131.5	76.2	1.5D	10	5076-6051
*2 1/2"	156.5	95.3	1.5D	10	5076-6064
*3"	176.5	114.3	1.5D	10	5076-6076
*4"	216.5	152.4	1.5D	10	5076-6102

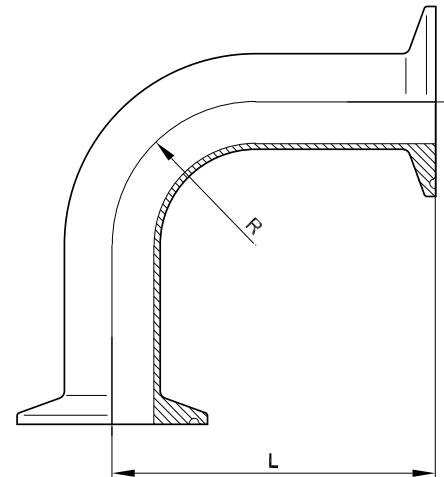

TECHNICAL DATA	
Associated Standards	*BS 4825-3 (1"-4" inclusive)
Material	316L Stainless Steel
Material Certification	BS EN 10204/DIN 50049 3.1 for all wetted parts
Finish	Welds removed ID & OD, Polished 0.8Ra (0.4 Ra available)
Pressure/Temperature	See table
Options	45°, 88°, 92° (Clamp 90° 1D bends also available)
Clamp Fittings Range	Unions, ferrules, blanks, tees, bends, hoseliners, adaptors, concentric & eccentric reducers, Y pieces
Seals	FDA & USP Class VI approved polymers including EPDM, Nitrile, Silicone, Platinum Cured Silicone, Encapsulated & Solid PTFE, Viton® (Viton is a registered trade mark of Dupont Dow Elastomers).
Notes	Dimensions are provided in good faith. Seals must be chosen for required operating medium and temperature
GENERAL CAPABILITIES	
Design and System Fabrication, Hygienic Process Plant, Project Management, In-house Manual and Orbital Welding, Machining, Fabrication and Polishing, Component Customisation	
Full materials certification, weld maps, logs, welder qualifications and weld procedures, pickling, passivation and ferroxyl certification.	

D5076-V03 ECN 725

CUSTOMISED STAINLESS STEEL SYSTEMS, FABRICATIONS AND COMPONENTS

Axium Process Ltd

Hendy Industrial Estate, Hendy, Swansea, UK SA4 0XP

Tel: +44 (0) 1792 883882

Fax: +44 (0) 1792 886049

Email: info@axiumprocess.com

Web: www.axiumprocess.com



All data is provided in good faith and is subject to change