

5020

Clamp Light Duty 304 BS4825

Nom size	A	B	R	Max Op Pressure (bar) @ 150 C	Stock No
1/2"	25.0	63.0	60.0	10	5020-4013
3/4"	25.0	63.0	60.0	10	5020-4013
1"	50.0	78.0	85.0	10	5020-4026
1 1/2"	50.0	78.0	85.0	10	5020-4026
2"	64.0	82.0	99.0	10	5020-4051
2 1/2"	77.0	89.0	112.0	10	5020-4064
3"	91.0	96.0	126.0	10	5020-4076
4"	119.0	110.0	154.0	10	5020-4102

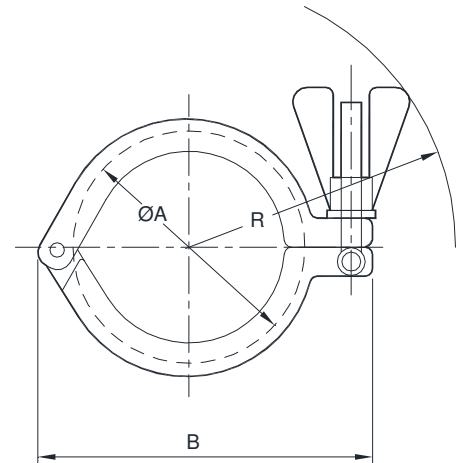

TECHNICAL DATA	
Associated Standards	1" – 4" = BS 4825-3, ASME BPE 2009, ISO 1127 (2852), DIN 32676, SMS 3008
Material	304 Stainless Steel
Material Certification	BS EN 10204/DIN 50049 3.1 for all wetted parts
Finish	External 0.8Ra as standard
Tolerance	+/- 1.0mm
Clamp Fittings Range	Unions, ferrules, blanks, tees, bends, hoseliners, adaptors, concentric & eccentric reducers, Y pieces
Seals	FDA & USP Class VI approved polymers including EPDM, Nitrile, Silicone, Platinum Cured Silicone, Encapsulated & Solid PTFE, Viton® (Viton is a registered trade mark of Dupont Dow Elastomers).
Notes	Dimensions are provided in good faith. Seals must be chosen for required operating medium and temperature
GENERAL CAPABILITIES	
Design and System Fabrication, Hygienic Process Plant, Project Management, In-house Manual and Orbital Welding, Machining, Fabrication and Polishing, Component Customisation	
Full materials certification, weld maps, logs, welder qualifications and weld procedures, pickling, passivation and ferroxyl certification.	

D5020-V02 ECN 725

CUSTOMISED STAINLESS STEEL SYSTEMS, FABRICATIONS AND COMPONENTS

Axium Process Ltd

Hendy Industrial Estate, Hendy, Swansea, UK SA4 0XP

Tel: +44 (0) 1792 883882

Fax: +44 (0) 1792 886049

Email: info@axiumprocess.com

Web: www.axiumprocess.com



FS 83081

All data is provided in good faith and is subject to change