

Saddle Clip (insert) 304

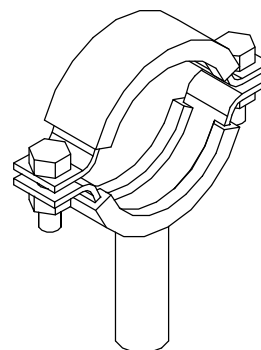
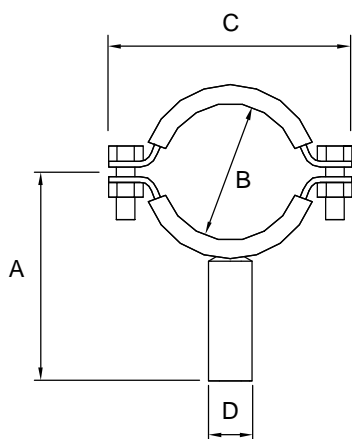

Nom size	A	B	C	D	Stock No
1/2"	90.0	12.7	50.0	19.0	0099-4013
3/4"	90.0	19.05	55.0	19.0	0099-4019
1"	90.0	25.4	61.0	19.0	0099-4026
1½"	90.0	38.0	74.0	19.0	0099-4038
2"	90.0	50.7	71.0	19.0	0099-4051
2½"	90.0	63.5	83.5	19.0	0099-4064
3"	90.0	76.2	96.0	19.0	0099-4076
4"	90.0	101.6	121.5	19.0	0099-4102
5"	90.0	127.0	147.0	19.0	0099-4127
6"	90.0	152.4	172.0	19.0	0099-4154

Technical Data:

- Material: 304 Stainless Steel
- Finish: Polished
- Pressure/Temperature: N/A
- Associated standards: N/A
- Applications : For holding and supporting various sizes of pipework within all industries
- Tolerance: +/- 0.5mm

- We stock a comprehensive range of RJT, IDF, SMS, DIN and BSP fittings including unions, ferrules, bends, tees, reducers, hoseliners and adaptors
- Components can be fabricated to customer specification
- Fabrication capabilities include frameworks, skid mounted systems, manifolds, jacketed assemblies, adaptors, flowplates and spool pieces.
- In-house services include machining, welding, fabrication, polishing.

D0099 – V01

NOTES

FORM No:FM002-V02

Axiom Process Ltd
Hendy Industrial Estate
Hendy, Swansea
SA4 0XP UK

- Dimensions are provided in good faith but maybe subject to change
- Seals must be chosen for required operating medium & temperature

(T) +44 (0)1792 883 882
 (F) +44 (0)1792 886 049
 (E) info@axiumprocess.com
 (W) www.axiumprocess.com