

5282

ASME BPE Clamp ended eccentric reducer 316L

Nom size		Dim	Stock number
A	B	L1	
3/4"	1/2"	50.8	5282-6019-013
1"	1/2"	63.5	5282-6026-013
1"	3/4"	50.8	5282-6026-019
1 1/2"	3/4"	76.2	5282-6038-019
1 1/2"	1"	76.2	5282-6038-026
2"	1"	127.0	5282-6051-026
2"	1 1/2"	76.2	5282-6051-038

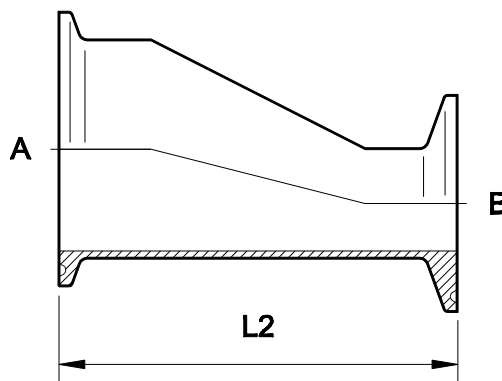

TECHNICAL DATA	
Associated Standards	ASME BPE - 2009
Material	316L Stainless Steel/LS 1.4435
Material Certification	BS EN 10204/DIN 50049 3.1 for all wetted parts
Finish	SF1 (0.5 µm, mechanical)
Pressure/Temperature	Up to 10 bar at 20°C
Tolerance	To ASME BPE tolerances
Options	Sizes up to 6" available We also supply plain ended options which are ASME BPE compliant
Clamp Fittings Range	Unions, ferrules, blanks, tees, bends, hoseliners, adaptors, concentric & eccentric reducers, Y pieces
Seals	FDA & USP Class VI approved polymers including EPDM, Nitrile, Silicone, Platinum Cured Silicone, Encapsulated & Solid PTFE, Viton® (Viton is a registered trade mark of Dupont Dow Elastomers).
Notes	Dimensions are provided in good faith. Seals must be chosen for required operating medium and temperature
GENERAL CAPABILITIES	
Design and System Fabrication, Hygienic Process Plant, Project Management, In-house Manual and Orbital Welding, Machining, Fabrication and Polishing, Component Customisation	
Full materials certification, weld maps, logs, welder qualifications and weld procedures, pickling, passivation and ferroxyl certification.	
To ASME BPE tolerances	

D5282-V01

CUSTOMISED STAINLESS STEEL SYSTEMS, FABRICATIONS AND COMPONENTS

Axium Process Ltd

Hendy Industrial Estate, Hendy, Swansea, UK SA4 0XP

Tel: +44 (0) 1792 883882

Fax: +44 (0) 1792 886049

Email: info@axiumprocess.com

Web: www.axiumprocess.com



FS 83081

All data is provided in good faith and is subject to change