

8074

Plain-ended 45° bend, 1.5D, Standard - 316L

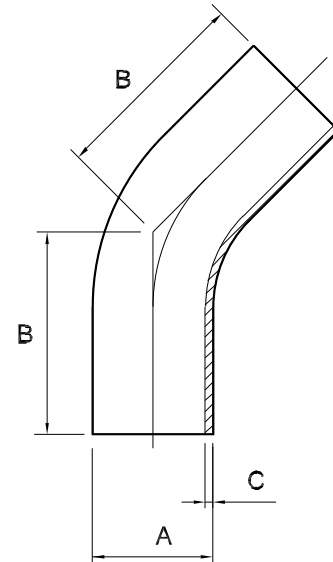

Nom size	A	B	R	C	Stock No
3/4"	19.1	19.4	28.6	1.65	8074-6019
1"	25.4	30.2	38.1	1.65	8074-6026
1 1/2"	38.1	41.3	57.2	1.65	8074-6038
2"	50.8	58.7	76.2	1.65	8074-6051
2 1/2"	63.5	76.2	95.3	1.65	8074-6064
3"	76.2	93.7	114.3	1.65	8074-6076
4"	101.6	122.2	152.4	2.11	8074-6102

TECHNICAL DATA	
Material	316L Stainless Steel
Material Certification	BS EN 10204/DIN 50049 3.1 for all wetted parts
Finish	ID polished to 1.0 µm Ra : OD Descaled to 2.5 µm Ra
Tolerance	+/- 1.0mm
Plain-Ended Fittings Range	Tees, 90°, 45° & 180° bends, hosetails, concentric & eccentric reducers, Y pieces, Crosses
Notes	Dimensions are provided in good faith. Seals must be chosen for required operating medium and temperature
GENERAL CAPABILITIES	
Design and System Fabrication, Hygienic Process Plant, Project Management, In-house Manual and Orbital Welding, Machining, Fabrication and Polishing, Component Customisation	
Full materials certification, weld maps, logs, welder qualifications and weld procedures, pickling, passivation and ferroxyl certification.	

D8074-V05 / ECN2268

CUSTOMISED STAINLESS STEEL SYSTEMS, FABRICATIONS AND COMPONENTS

Axium Process Ltd

Hendy Industrial Estate, Hendy, Swansea, UK SA4 0XP

Tel: +44 (0) 1792 883882

Fax: +44 (0) 1792 886049

Email: info@axiumprocess.com

Web: www.axiumprocess.com



All data is provided in good faith and is subject to change